



Environmental Health and Safety

Eye Wash and Safety Showers

Bio-Tech Solutions

Spill Containment



Unicare[™]
Caring For Your Safety

Emergency Eye Wash and Safety Showers

The widest range of effective Eye/Face Wash and Safety Showers equipment for the chemical process and engineering industries.

Primary International Regulation requires that

“Where the eyes or body of any person may be exposed to injurious corrosive materials, suitable facilities to quick drenching or flushing of the eyes and body shall be provided within the work area for immediate emergency use.”

We have made a substantial investment in custom-designed test equipment continually updated so that our products are tested to current and conform to National and International standards viz BIS (IS : 10592) , ANSI (Z 358.1 2009), EN (15154 Part 1 & 2) etc.

Specifications

(I) Shower

1. Height of Shower Head : 2100 mm to 2400mm
2. Flow Rate : More than 110 LPM at 30 PSI (2 kg/cm²)
3. Diameter of Water Column : 510mm at 1500mm from ground level
4. Flow Pattern : Evenly distributed. It gives 50% 10% of water in 400mm dia. circle and 95% of water in 800mm dia. circle at 700mm below shower head.
5. Valve Operation : i. Operated within one second or less and stay open till intentionally closed (stay-open construction)
ii. The force required to open valve is less than 100 N
6. Shower Head : Not easily removable or cannot change its direction
7. Material of Construction : Anti-Corrosive materials like galvanized iron, stainless steel, brass, thermoplastic etc.

(II) Eye/Face Wash Fountain

1. Height of Eyewash Nozzles : 1065mm +/- 25
2. Flow Rate through Nozzles : 25 LPM
3. Water Spray Jet from Nozzles : Smooth and not injurious to user
4. Height of Spray Jet from Nozzles : 100 mm to 300 mm
5. Valve Operation : i. Operate within 1 second or less and stays open till shut off intentionally keeping user's hand free for cleaning eyes.
ii. Force required is less than 100 N.
6. Pressure Control : Automatic pressure compensators are used in the nozzles
7. Material of Construction : Anti-Corrosive materials like galvanized iron, stainless steel, brass, thermoplastic etc.

Emergency Shower & Eye/ Face Wash units are to be installed at a place accessible from 3 sites without any obstruction and maximum 10 seconds (50 feet away) from the workplace.

It must be installed at the same level of the workplace so that victim need not go up or down to reach the unit and also away from electrical & chemical installation which will be affected by water.

Only potable water is recommended for Eye /Face Wash & Emergency Shower Units.



Eye Wash



Safety Shower



Combination Shower

The key feature of the Eye/ Face Wash is the ability of the cushion-flow atomizer heads to deliver a soft, feather-like flow effect to the injured ocular area.

RECEPTOR BOWL

High visibility yellow extra-large Atomizer Heads Cyclac Receptor Bowl resistant to damage from alkalis, salt solutions, oils, most acids.

ATOMISER HEADS

Twin cushion-flow Cyclac Atomizer Heads in high visibility Yellow/Black with flip-flop dust covers that protect heads that automatically release with water pressure

ACTIVATION

Yellow Cyclac Push Plate/ Foot Pedal operated Stay-open Brass Ball Valve with Stainless Steel Ball and Spindle.

STREAM CONTROL

Steady water flow under varying pressures assured with automatic pressure compensators for 30- 90 PSI.

SUPPLY

1/2" BSP

Recommended pressure: 30 PSI/ 2 kg/cm2

DRAIN

1 1/4" BSP

NET SHIPPING WEIGHT

LSE 1 : 8 kg

LSE 1A : 2 kg

LSE 1B : 3 kg

LSE 2 : 9 kg



**LSE 1 GI: EYE/ FACE WASH
- PUSH LEVER OPERATED**

**LSE 2 GI: EYE/ FACE WASH
- FOOT PEDAL OPERATED**



**LSE 1A GI : EYE/ FACE WASH AND BODY SPRAY
WITH 6' HOSE, SQUEEZE VALVE - WALL BRACKETED**



**LSE 1B GI: EYE/ FACE WASH PUSH LEVER
OPERATED - WALL MOUNTED**

Models in Stainless Steel



LSE1 CSS 304: EYE/FACE WASH
- PUSH LEVER OPERATED



LSE1/2 CSS C (with cover): EYE/FACE WASH
- PUSH+PEDAL LEVER OPERATED
WITH PROTECTIVE COVER
to prevent air borne contaminants
from entering the eyewash heads.



LSE2 CSS 304: EYE/FACE WASH
- FOOT PEDAL OPERATED

PORTABLE EYE WASH UPEW 14

Self Contained unit provides 15 minutes of decontaminating water flow.

34 liters capacity for easier transport.

Small compact size with carrying handle making it more convenient for portability and transport.

Chemical Resistant high density polyethylene material.

Large filling cap for easy filling, cleaning and inspection.

The Eye wash is activated by simply pulling the retractable tray.

Retractable tray protects against air borne contaminants.

High visibility colours provide quicker identification for the victim in distress.

Translucent Green container indicates water level.

Mounted on bracket supplied that easily bolts to wall.

Applications:

Chemical and Pharmaceutical work sites

Fire and Emergency Teams

Drivers carrying dangerous substances

Remote places in Mining, Agriculture and Construction



UPEW 14

EMERGENCY EYE WASH BOTTLE - UEWB 12 (Capacity 600ml)

When seconds count!

Permits immediate flushing for the crucial first few seconds of an eye injury by flushing the eyes in the event of an accident involving acids, caustics and other water-soluble irritants.

The Eye cup is specially designed to give the eye as much water as possible without unnecessary spills, while also helping to keep the eye open.

The snap-on dust cover prevents air borne contamination.

The drain tube provided removes all used fluid preventing the contamination fluid from entering into the bottle.

Portable, light-weight, easy-to-use at any work place.



UEWB 12

Safety Drench Shower

The main feature of the Drench Shower is to deliver a deluge of water in case corrosive material contacts portions of the body. In addition it also offers first aid in the event of clothing fires. Because of the huge quantity of water available (Approx. 150 liters per minute) it bears no resemblance to the normal bathroom showers in design and performance.

LSS 9 GI: DRENCH SHOWER - PULL ROD OPERATED

SHOWER HEAD

Extra large Cicolac drench shower head with perforated spreader ensures complete drenching of the victim in seconds.

ACTIVATION

Yellow Galvanized Pull Rod

SUPPLY

1 ¼" BSP

NET SHIPPING WEIGHT

LSS 9: 15 kg



LSS 9 GI:
DRENCH SHOWER COMBINATION SHOWER
- PULL ROD OPERATED & EYE WASH UNIT

Combination Units

These models are designed to provide a complete safety station for immediate first-aid. In one location both Eye/Face Wash fountain and Drench Shower ensure instant flushing of the eyes and/or body with copious amounts of water. Shower and Eye Wash are operated simultaneously or independently.

ATOMIZER HEADS

Twin cushion-flow Cicolac Atomizer Heads in high visibility Yellow/Black with flip-flop dust covers that protect heads that automatically release with water pressure.

SHOWER HEAD

Extra large Cicolac drench shower head with perforated spreader ensures complete drenching of the victim in seconds.

RECEPTOR BOWL

High visibility Yellow extra-large Cicolac Receptor Bowl resistant to damage from alkalies, salt solutions, oils, most acids.

ACTIVATION

For Eye Wash: Yellow Cicolac Push plate/ Foot pedal operated Self-closing Brass Ball Valve with Stainless Steel Ball and Spindle.

For Shower: Yellow Galvanized Pull Rod/ Platform

STREAM CONTROL

For Eye Wash: Steady water flow under varying pressures assured with automatic pressure compensators for 30- 90 PSI

SUPPLY

1 ¼" BSP

Recommended pressure: 30 PSI / 2 kg/cm²

DRAIN

1 ¼" BSP for LSES 7 & LSES 8

(No drain for other models.)

NET SHIPPING WEIGHT

LSES 3 : 28 kg

LSES 4 : 28 kg

LSES 6 : 14 kg

LSES 7 : 20 kg

LSES 8 : 22 kg

Also Available in Stainless Steel



LSES 3 GI: EYE/FACE WASH AND
SHOWER OPERATE
SIMULTANEOUSLY BY
WALK-ON PLATFORM



LSES 4 GI: EYE/FACE WASH AND
SHOWER OPERATE SIMULTANEOUSLY
OR EYE/FACE WASH
INDEPENDENTLY,
BY WALK-ON PLATFORM

Models also available in Stainless Steel



LSES 7 GI: EYE/FACE WASH AND SHOWER OPERATE INDEPENDENTLY BY PUSH LEVER AND PULL ROD



LSES 8 GI: EYE/FACE WASH AND SHOWER OPERATE INDEPENDENTLY BY FOOT PEDAL AND PULL ROD



LSES 7/8 GI: EMERGENCY COMBINATION EYE/FACE WASH PUSH LEVER & PEDAL OPERATED & DRENCH SHOWER - PULL ROD OPERATED



LSES 7 CSS 304



LSES 8 CSS 304



LSES 7/8 CSS 304



Decontamination Units

These units are essential in areas where large amounts of chemicals are used, handled or stored or where chemical splash hazards exist. The decontamination unit is a complete safety station which immediately discharges copious amounts of water on the whole body of the injured person upon the activation of a single valve or walk-on platform.

These units are designed to be located in areas of high hazard where space is limited. They can be mounted against a wall and still leave an open space. Each unit consists of several self-cleaning spray nozzles plus weep sprays that provides overall body saturation within a matter of seconds.



ACTIVATION

Shower is activated with instant action Ball valve with easy-to-locate Yellow Cyclocac Push-plate or by weight on walk-on Platform to operate the Flush Valve.

SUPPLY

1" BSP

Recommended pressure: 30 PSI / 2 kg/cm²

NET SHIPPING WEIGHT

LMNS 10 : 35 kg

LMNS 11 : 23 kg

LMNS 10: MULTIPLE NOZZLE DECONTAMINATION UNITS - OPERATED BY WALK-ON PLATFORM

LMNS 11: MULTIPLE NOZZLE DECONTAMINATION UNITS - OPERATED BY **PUSH** LEVER



LMNS 10

Also Available in Stainless Steel

Accessories For Emergency Eye Wash & Safety Shower



SS EYE WASH VALVE WITH SS PUSH HANDLE



BRASS EYE WASH VALVE WITH PUSH HANDLE

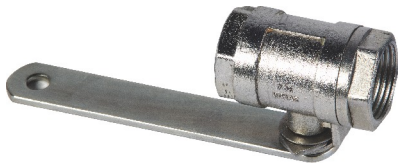

SS SHOWER VALVE WITH SS BALL & STEM



BRASS SHOWER VALVE WITH SS BALL & STEM

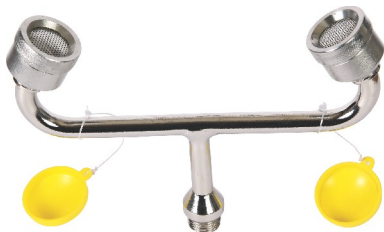

SS SLIM-LINE ATOMISER UNIT
with FLIP-FLOP DUST COVERS



ABS ATOMISER UNIT
with FLIP-FLOP DUST COVERS



SS RECEPTOR BOWL



ABS RECEPTOR BOWL



SS SHOWER DOME

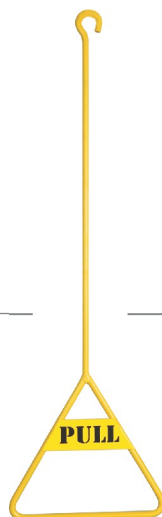

PULL ROD



ABS SHOWER DOME

Technical Line Drawings for Emergency Eye-Wash & Safety Showers

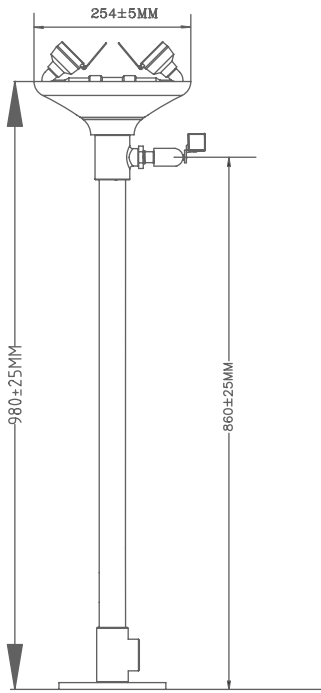

LSE 1
Eye / Face Wash - PUSH lever operated.

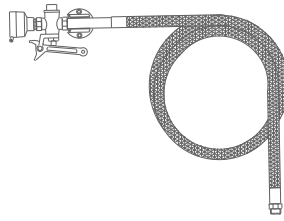

LSE 1A
Eye/Face Wash and Body Spray
with 6' Hose, Squeeze
Valve - wall bracketed.

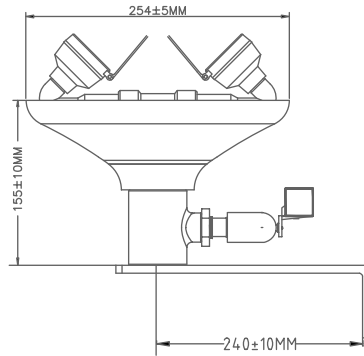

LSE 1B
Eye/Face Wash - PUSH lever operated -
Wall mounted.

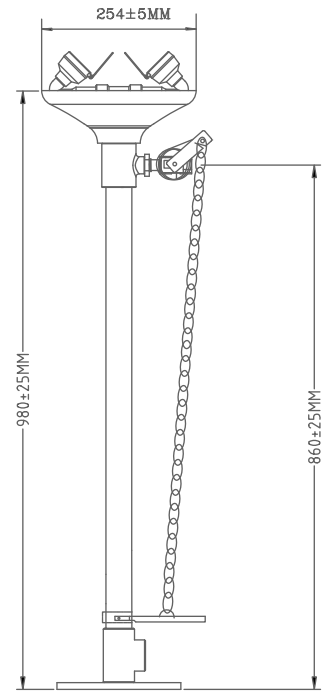

LSE 2
Eye/Face Wash - FOOT Pedal Operated

**EYE/FACE WASH
(SECTION ILLUSTRATION)**
Wide-open design prevents
internal clogging.

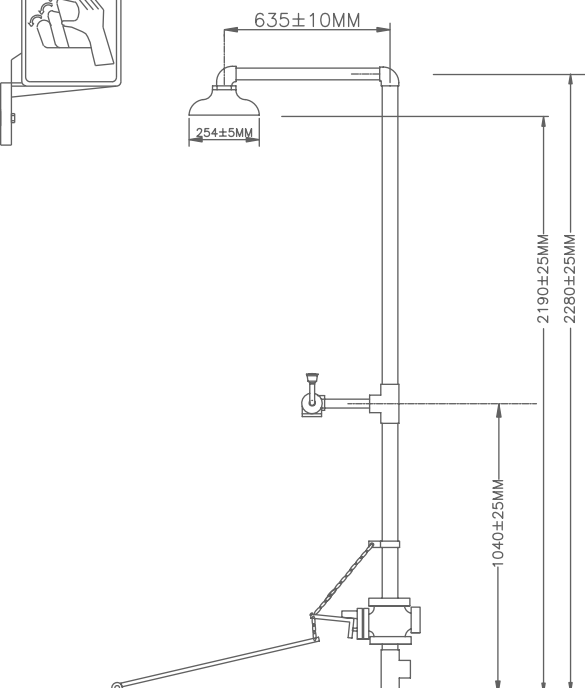
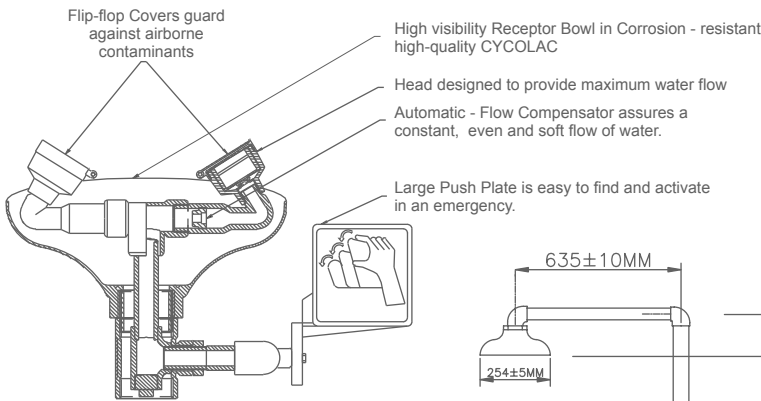

LSES 3
Eye/Face Wash and shower operate simultaneously
by Walk-on platform.

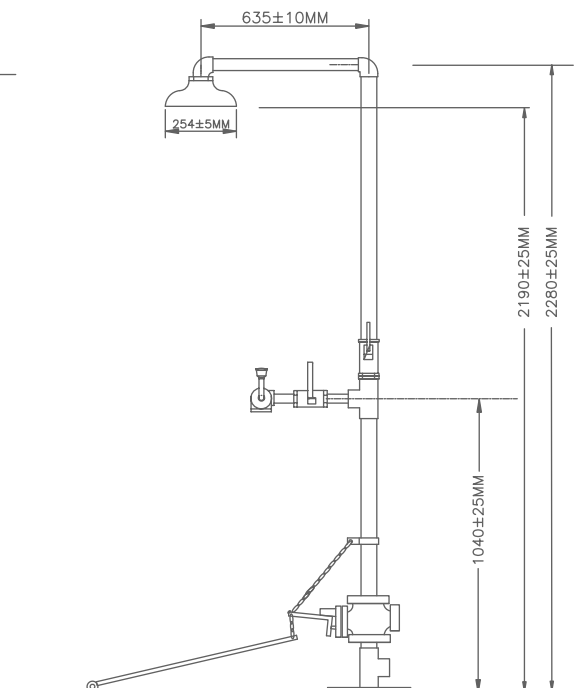

LSES 4
Eye/Face wash and Shower operate
simultaneously or Eye/Face wash independent by
Walk - on platform.

Technical Line Drawings for Emergency Eye-Wash & Safety Showers

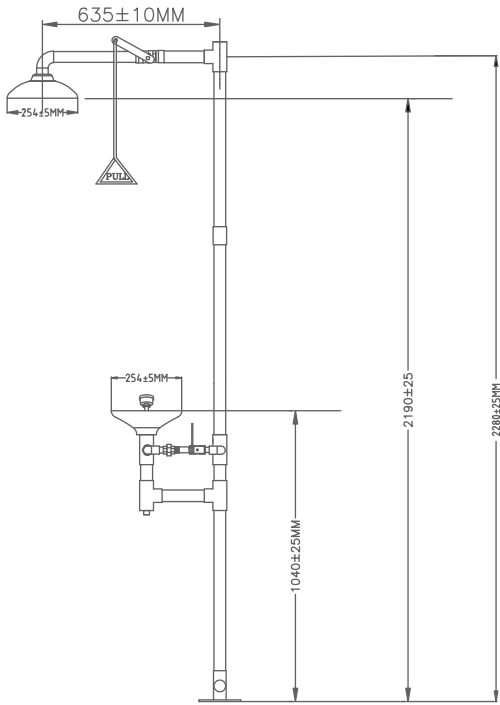

LSES 7
Eye/Face Wash and Shower operate independently by **PUSH** lever and **PULL** rod.

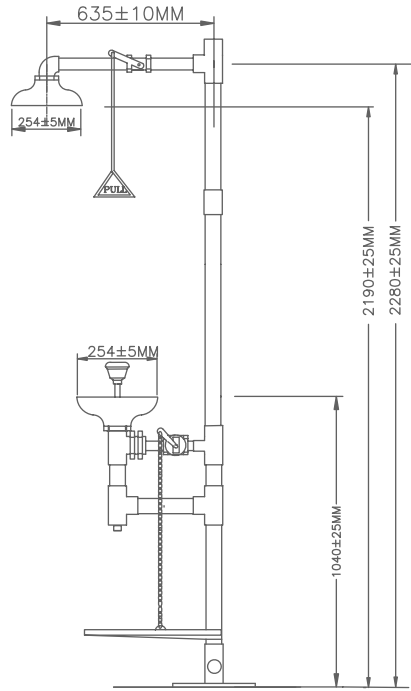

LSES 8
Eye / Face Wash and Shower operate independently by **FOOT** pedal and **PULL** rod.

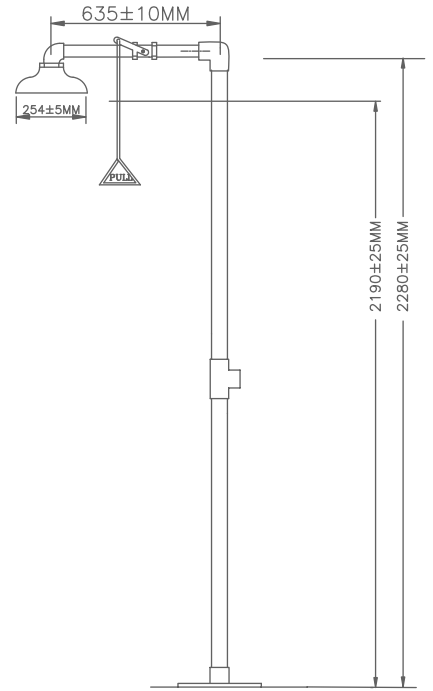

LSS 9
Drench Shower - **PULL** rod operated

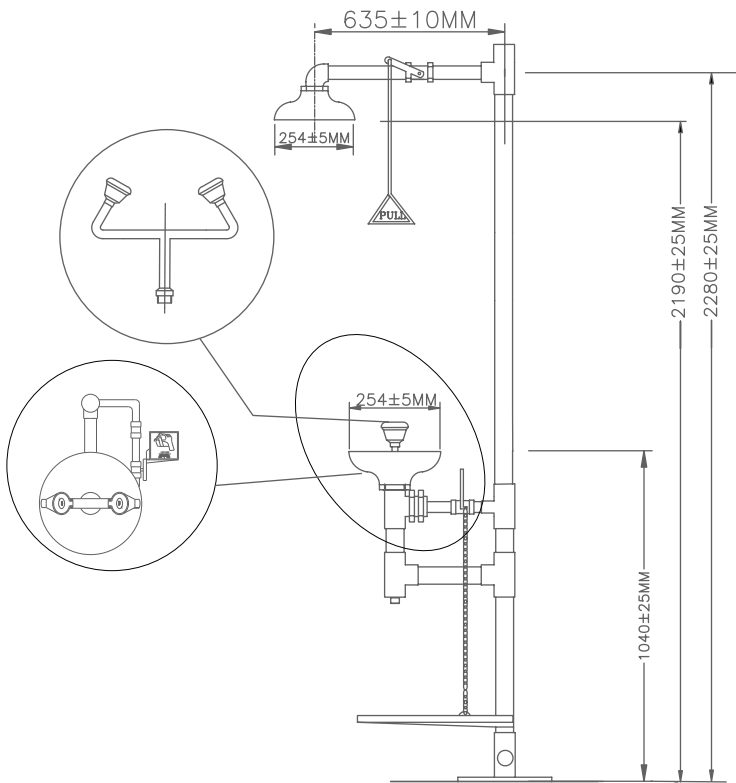

LSES 7/8 GI
Combination Eye/Face Wash
PUSH lever & Pedal Operated
& Drench Shower - **PULL** rod operated

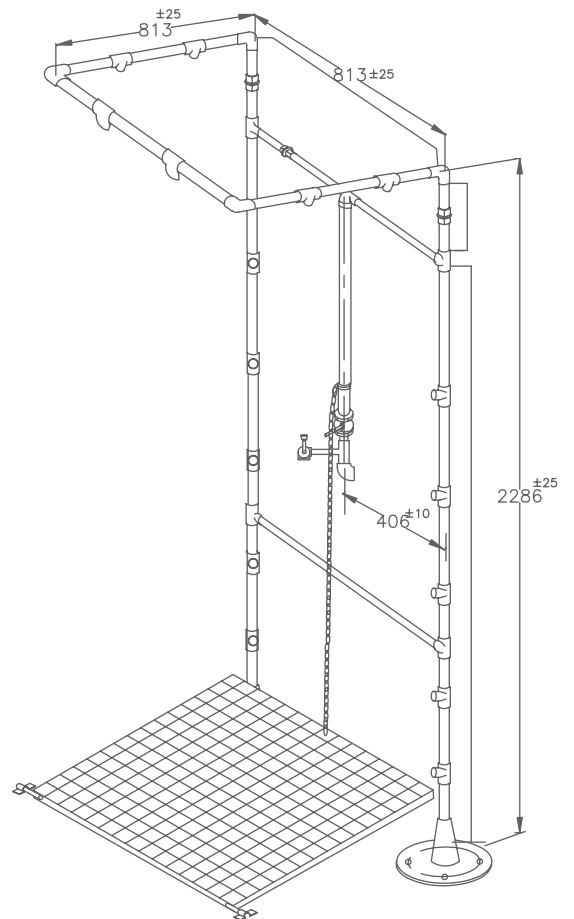

LMNS 10
Operated by walk - on platform.

Unicare has entered into a business arrangement with Fermenta Biotech Limited (FBL), a Research and Development based, biotechnology company with core focus on eco-efficient technologies and products for sustainable development. Apart from other products, FBL offers eco-efficient and cost-effective biotech solutions for various applications in the environmental segment. Under this business arrangement, Unicare will promote the following products and services of FBL in the Indian market.

Products and Services

A. Bio-products

- a. Bio-enzyme product(s) for waste water treatment(STP/ETP/septic tanks/), Fermsept[®] series
- b. Bio-enzyme product(s) for lake and pond water management (e.g algal control)
- c. Bio-enzyme product(s) for solid waste management
 - i. Oil sludge bioremediation
 - ii. Municipal solid waste management
 - iii. Distillery waste management (e.g spent wash / presmud)
- d. Biofilters for treatment of hazardous industrial gas emissions
- e. Bio-catalysts for nitrification/ denitrification of industrial waste water

B. Services

- a. Project Consultancy services for enhancing efficiency of water treatment plants (STP/ETP/CETP)
- b. Project Consultancy services for enhancing efficiency of biogas / biocomposting (e.g presmud composting)
- c. Project Consultancy & design for cost effective waste water treatment systems
- d. Project consultancy services for the treatment of industrial effluents (e.g. coke oven effluent)
- e. Project consultancy services for development of Bio-filters
- f. Bioremediation services
 - i. Lake and pond water bioremediation
 - ii. Oil sludge and other petroleum sludge bioremediation
 - iii. Soil and ground water bioremediation (e.g oil pollution / chemical pollution)





DUAL CYLINDER DOLLY-7302-BK

DUAL CYLINDER DOLLY-7302-BK

Features:

Accommodates any two cylinders, each up to 12" in diameter including class 300 SCF industrial gas cylinders and No. 5 acetylene cylinders
Load Bearing Capacity UDL : 500lbs / 227kg



POLY-SLIM-LINE™ 6000 (5400-YE-D)

POLY-SLIM-LINE™ 6000 (5400-YE-D)

Features:

Secondary containment system
Load Bearing Capacity UDL: 6000lbs. / 2722kg
Sump Capacity: 66gals./ 250liters

Approvals:

Meets EPA 40 CFR 264.175, SPCC and NPDES regulations



POLY DOLLY® - 5300 -YE

POLY DOLLY® - 5300 -YE

Features:

Transports 55 gallon drums with ease, tilts to become an efficient self-dispensing station, and acts as its own secondary containment unit
Tough polyethylene construction, cannot rust or corrode
Hold up to 600 lbs to cover most applications
Load Bearing Capacity UDL : 600lbs. / 273kg
Sump Capacity: 80gal. / 303kg

Approvals:

Meets EPA 40 CFR 264.175, SPCC and NPDES regulations